

Flow adsorption microcalorimetry

A.J. Groszek*

Microscal Ltd., 79 Southern Row, London W10 5AL, UK

1. Introduction

Flow adsorption techniques are now widely recognised as important methods of studying adsorption/desorption phenomena at solid/fluid interfaces. Pioneering work by the author some years ago demonstrated the power of a simple-flow technique for the determination of the heats of adsorption at solid–liquid interfaces [1] which was, subsequently, used for the measurement of the heats of adsorption of gases and vapours [2]. A new feature in this calorimeter was the use of a single calorimetric cell for the measurement of temperature changes in the adsorbent bed due to adsorption/desorption phenomena, employing the cold junction of thermocouples as the reference sensors. Heat effects produced during surface interactions were rapidly dissipated in the heat sink constituted by a water jacket in direct contact with the glass walls of the calorimetric cell. The reference cold junctions were placed in water adjoining the glass walls, while the measuring heat junctions were in direct contact with the adsorbent. Heat loss from the cell occurred within a few minutes after surface interactions took place and in this way the heats of adsorption/desorption on granulated solids could be measured effectively under isothermal conditions.

This type of microcalorimetry has been referred to as diathermal calorimetry and has been adopted by most adsorption calorimeters of Tian–Calvet type [3]. A similar principle, using a single adsorption cell, was used in the first commercial version of a flow macro-

calorimeter developed by MICROSCAL [4]. Subsequently SETARAM and LKB companies produced their own versions of flow adsorption calorimeters, the latter being more widely used. The LKB calorimeter is currently available as thermal activity monitor (TAM). An example of its use is provided by the work of Os et al. [5]. In the Microscal instrument thermocouples were replaced by thermistors and the water jacket by a metal block surrounding a small PTFE cell accommodating 0.17 cc of adsorbent bed [4,6]. A schematic diagram of a recent model of this calorimeter is shown in Fig. 1.

This paper reviews extensive work by the author with the use of Microscal flow adsorption microcalorimeters, which have led to the discoveries of new aspects of surface chemistry of inorganic solids [7,8] and the behaviour of adsorbates at different surface coverages [9,10]. The work resulted in the development of new selective adsorption processes [11,12], competitive and co-operative adsorption phenomena [10], a better understanding of the role of adsorption in lubrication [13], surface reactions [14,15] dispersion technology [16] and determination of polar- and graphitic-surface sites on carbonaceous solids [17,18].

2. Main results and developments – The first two decades

The initial flow adsorption microcalorimetry work was discussed at a Symposium at the BP Research Centre in March 1971 [19] at which Sir Eric Rideal expressed strong support for the flow adsorption methodology and stressed its great potential for work

*Corresponding author.

xlfmt
980114
160000

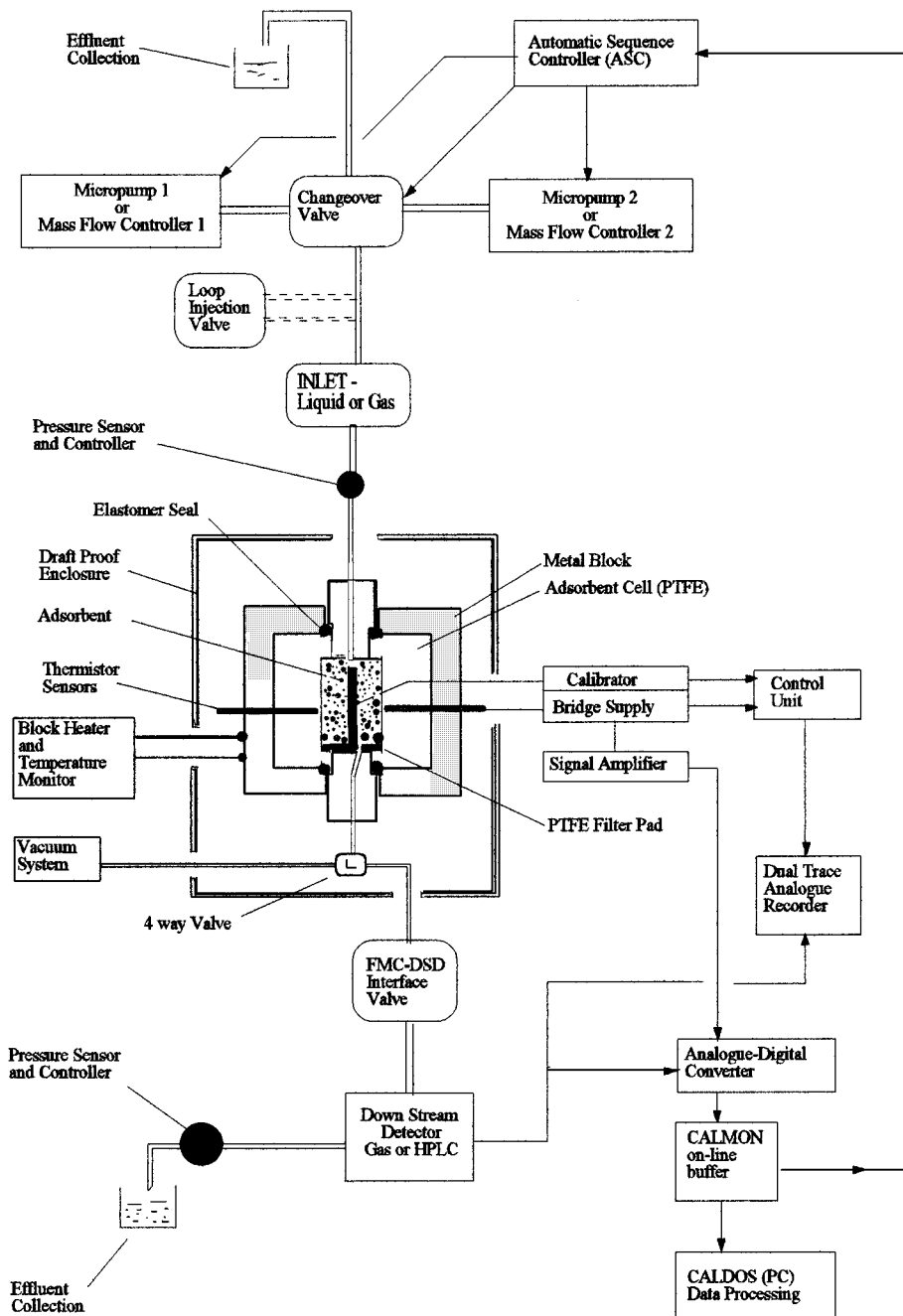

Fig. 1. Microscale flow microcalorimeter.

on adsorption at liquid–solid and solid–gas interfaces. A number of papers at the Symposium described several applications of the flow methods for the deter-

mination of the heats of adsorption from solution by a stepwise sequential displacement of solvent by increasingly concentrated solutions. The increments

in solute concentrations were made sufficiently small to eliminate interference from the heats of mixing, and an adequate period of time for solution percolation was allowed to obtain full adsorbent saturation. The heats of adsorption determined in this way followed adsorption isotherms which could be determined separately. Individual points on the adsorption isotherms could be related to the relevant heats of adsorption and differential and integral molar heats of adsorption calculated.

Many isotherms (determined for the adsorption of low molecular weight alcohols, such as *n*-butanol, from normal alkanes such as *n*-heptane) on metal oxides obeyed the Langmuir equation applicable to dilute solutions, and this equation could, therefore, be used to obtain the free energy change ΔG from the relationship:

$$\Delta G = \Delta H + T\Delta S \quad (1)$$

where ΔH is the measured heat of adsorption, T the absolute temperature and ΔS the entropy change. This method was used by the author to obtain thermodynamic parameters characterising the selective adsorption of *n*-paraffins on graphitic carbons [11]. In the case of dilute solutions for which the heats of adsorptions were proportional to the amounts of adsorption (a necessary condition for the conformity with the Langmuir isotherm), the equilibrium constants could be determined directly from the heats of adsorption, as proposed by Allen and Patel [10] using the relationship:

$$\frac{C}{q} = \frac{1}{kq_0} + \frac{C}{q_0} \quad (2)$$

where C is the solute concentration producing the heat of adsorption q , q_0 the heat of adsorption corresponding to monolayer coverage and k the equilibrium constant.

The free energy of adsorption can be evaluated using the well-known equation:

$$-\Delta G = RT \ln k \quad (3)$$

The values of ΔG evaluated, in this way, could be substituted into Eq. (1) to obtain the entropy change ΔS , as was shown by the adsorption of *n*-paraffins and alcohols on graphitic carbons [11]. Furthermore, if the

equilibrium constants are determined at two different temperatures, T_1 and T_2 , and the corresponding heats of adsorption are also determined, the change of entropy of adsorption occurring between these two temperatures can be calculated from the individual values of entropy changes ΔS_1 and ΔS_2 occurring at temperatures T_1 and T_2 , using Eq. (1).

A flow-calorimetric study of the adsorption of long chain *n*-paraffins on the graphitic basal planes from *n*-heptane indicated the formation of a monolayer composed of the close-packed *n*-paraffin molecules [11]. This unexpected conclusion was confirmed several years later by STM studies by McGonigal et al. [20] and X-ray electron diffraction work by Morishe et al. [21] demonstrating the effectiveness of the flow adsorption techniques for the prediction of adsorbate structures on solid surfaces.

The heats of adsorption from dilute solutions forming well-defined plateaux at relatively low solute concentrations were used by the author for the determination of specific surface areas of metal oxides [22]. The surface areas were determined by saturating the powdered solids placed in the calorimetric cell with a solution of *n*-butanol in *n*-heptane, known to form a close-packed monolayer on the oxide surfaces and determining the resulting integral heat of a monolayer formation. The heats proved to be proportional to the specific surface areas for a large number of polar solids and correlated well with their BET (N_2) surface areas. An example of a family of iron oxides which gave an excellent correlation of this type is shown in Fig. 2. The levels of the heats of adsorption plateaux corresponded to the individual surface areas was the correlating factor of 1 J g^{-1} being equivalent to $11.3 \text{ m}^2 \text{ g}^{-1}$ of the surface.

It was later found that the factor for carbons and graphites is lower, i.e. 1 J g^{-1} corresponds to the polar area of $6.7 \text{ m}^2 \text{ g}^{-1}$ [11]. This polar area constitutes only a small part of the total surface area as determined by N_2 adsorption [18] or from the heat of adsorption of *n*-butanol from water, which can be used for the estimation of the specific area of hydrophobic sites in microporous solids [23].

The determination of the area of polar sites in graphitic carbons was used in the development of novel supports for catalysts, after it was realised that an important criterion for the choice of the supports is the high ratio of the basal plane area to the area of

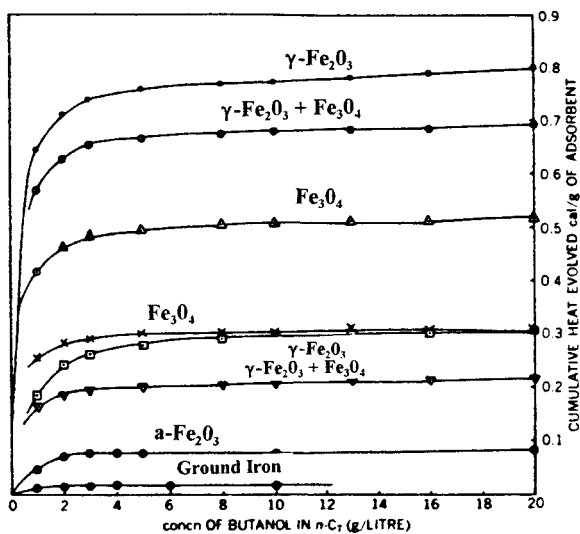

Fig. 2. Cumulative heats of adsorption of *n*-butanol from *n*-heptane on various iron oxides and iron powder. The integral heat of adsorption from the solution containing 2 g/l of *n*-butanol was used for the estimation of the specific surface area of the powders. All the isotherms conform with the Langmuir equation.

polar sites. This finding provided a key to the development of a series of superior novel catalysts for ammonia production [24].

The best carbon supports were those having a reduced number of polar sites, but an increased accessible basal plane area. Generally, improved catalytic results were obtained with the ratios of basal plane to polar sites being above 30 : 1. It was found later by the author that a small number of residual polar sites on graphitized or partly graphitized carbons have exceptionally high affinity for transition-metal salts. The affinity could be precisely evaluated by determining the heats of irreversibly adsorbed metal salts on individual carbon supports, as described below.

3. Some recent results and developments

3.1. Simultaneous determination of heats and amounts of adsorption

The applications of flow microcalorimetry were significantly broadened by the work of Fowkes et al., who developed a new method for combining the heat measurements with the determination of the

corresponding amounts of adsorption by employing on-line downstream detectors [25]. In this way, the differential and integral enthalpies of adsorption could be simultaneously and accurately determined on the same time scale. It was found that the heats and amounts of adsorption measured by the flow method correlated very well with the adsorption determined by conventional batch methods [26,27].

Attempts were made previously to measure simultaneously the heats and amounts of adsorption in flow adsorption systems. This has been recently reviewed by Kiraly and Dekany [28]. The methods used were based on the determination of adsorption from the retention times of the solutes leaving the adsorbent bed, the retention times being computed by various integration routines such as trapezoidal rule. This was not a reliable procedure and was not considered suitable for the deduction of adsorption isotherms [29], especially for adsorbents giving non-equilibrium effects during selective adsorption.

The Fowkes methodology was adopted by Groszek and Partyka for the calculation of the molar heats of adsorption of *n*-butanol on graphitised carbons and other solids and proved to be a sensitive, reliable and accurate procedure for simultaneous determination of the amounts and heats of adsorption and desorption [23]. The progress of adsorption was continuously monitored by the evolution of heat measured by thermistors sensing temperature changes in the adsorbent bed and at the same time solute transfer from solution to the adsorbent surface was monitored by measuring concentration changes in the effluent leaving the adsorbent and passing through a RI or UV detector. The temperature and solution concentration data were digitized, stored and, subsequently, processed using appropriate software. The data could then be related to thermal and concentration changes obtained for a bed of inert, non-adsorbing powder through which the same solutions were passed at the same flow rates and temperatures as those for the adsorbing bed. The two sets of data were then matched and processed by the computer and presented in the form of net heat and matter transfer for both adsorption/desorption cycles, as shown in Fig. 3(a) and (b) for the adsorption of *n*-butanol from water on graphitised carbon (graphon) at 25°C.

The curves in Fig. 3(a) show changes in refractive index with time occurring during percolation of 10 g/l

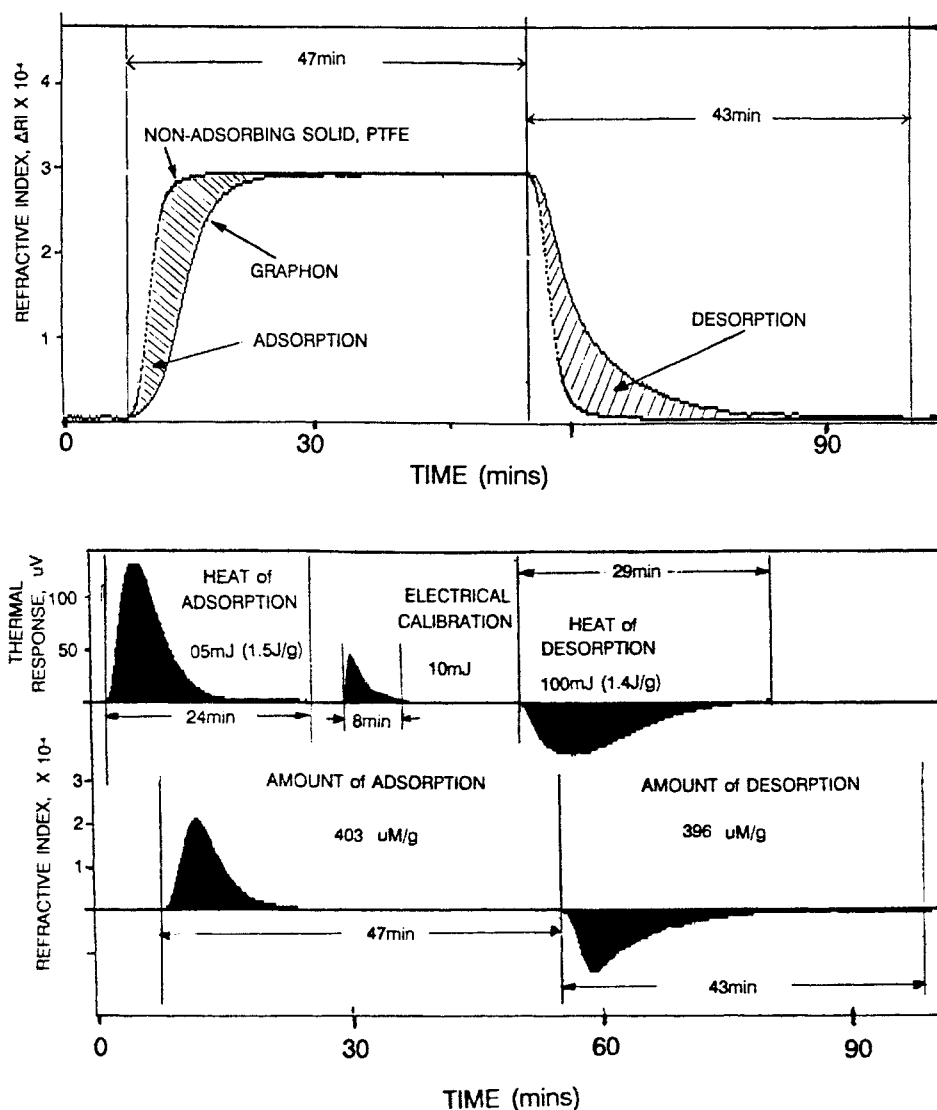

Fig. 3. Heats and amounts of adsorption of *n*-butanol from 10 g/l solution in water on graphitized carbon black (graphon) at 25°C: (a) Changes of refractive index in the effluent leaving a bed of 0.069 g of graphon at 25°C. Flow rate of solvent and solutions – 3 ml h⁻¹; (b) Differential heat of adsorption and adsorption curves corresponding to RI changes in Fig. 3(a).

solution of *n*-butanol in water through an inert PTFE powder and the graphitic carbon beds having a volume of 0.17 cc. The refractive index was measured differentially (difference between pure water and the solution) and increased in both cases from 0 to 3×10^{-4} RI units following different paths and producing different time–RI profiles. It should be noted that the retention time for the PTFE and carbon powders was identical in this case, but the rates of RI variations with time were

different due to adsorption taking place on graphon, but not on the inert powder. As the detector response was proportional to the solution concentration, the shaded area between the two curves represented the total amount of adsorption which took place during the percolation of the solution. Processing of the thermal and concentration data using Microscal software, gave adsorption and desorption peaks shown in Fig. 3(b) together with the corresponding heat-evolution peaks.

The latter also represented differential quantities resulting from the different outputs of the measuring and reference thermistors. Individual points on the heat and concentration peaks represent differential quantities which in the case of the solution curve express the rates of adsorption. Calibration is provided by a steady detector (DSD) response (baseline shift) reached after complete saturation of the adsorbent. Calibration of thermal effects is achieved by dissipation of known electrical energy in situ within the adsorbent bed under flowing conditions. The data obtained in this way provide differential and integral enthalpies of adsorption and information on the kinetics of adsorption obtained under the conditions of the experiment, i.e. flow rate of solution, volume and packing density of adsorbent bed and temperature.

The results obtained in Fig. 3 agree very well with the heats of adsorption of *n*-butanol on a graphitised carbon black obtained by Kiraly and Dekany from the determination of the heats of immersion [29] under static conditions, as well as with the results reported in the recent work by Lagerge et al. [30].

Flow adsorption microcalorimetric techniques have developed significantly in recent years and can now provide reliable data on heats and amounts sorbed for liquid and gaseous mixtures at a range of temperatures up to 150°C, for solid adsorbents in the form of powders, filaments, ribbons and pellets and at pressures up to 5 barg, (bargauge, 1 atm = ϕ bargauge) for liquids and 50 barg for gases.

A schematic diagram of the current Microscal flow adsorption system is shown in Fig. 4. The adsorbent in the bed can be evacuated and wetted with liquids generating heats of wetting, which can approximate the heats of wetting obtained in static calorimeters under the same conditions (degree of adsorbent evacuation and temperatures of the adsorbent and the wetting liquid). After wetting and the establishment of thermal equilibrium the fluid (carrier liquid) is percolated through the adsorbent at a constant rate using a precision syringe pump. Individual solutions are supplied to the adsorbent at the same flow rate as that of the carrier liquid. The pressures in the solvent and solution lines have to be adjusted to a value not differing by more than 0.05 barg to avoid disturbance of the base line during changeover between carrier liquid and solutions.

Adsorptions from volatile solvents can be studied at elevated temperatures by applying appropriate back pressures at the point of effluent exit from the DSD. For example, adsorption from aqueous solutions can be carried out at 120°C when the back pressure is increased to 2.5 barg [31].

3.2. Adsorption from gases

Essentially, the same situation exists when the experiments are carried out with gases. The gas flows are regulated by mass flow controllers and the thermal adsorption effects as well as the amounts of adsorption measured in a similar way to that employed for the solutions. The downstream detectors used in this case are those normally employed in gas chromatography. An important feature of the system developed by Microscal is that the gas pressure in the adsorbent cell can be increased up to 50 barg permitting the evaluation of the heats of gas sorption caused by a stepwise increase of pressure under static conditions. An illustration of such effects for active carbon–methane systems is shown in Fig. 5.

Adsorption from gas mixtures can be carried out, of course, under flowing conditions at various pressures and temperatures up to 200°C. The procedures used are similar to those used for adsorption from liquid mixtures, but the flow rates used are generally faster for gases, being of the order of 1 ml min⁻¹ rather than 0.05 ml min⁻¹ usually employed with liquids.

Examples of gas adsorption work carried out with flow-microcalorimetric techniques are provided by Thomas et al. [32] and Groszek [33]. The latter work demonstrated that the heat of adsorption of oxygen is, generally, greater on active carbons than that of N₂ and that the difference is especially marked for carbon molecular sieves. It was concluded that the high heat of adsorption of oxygen is partly responsible for its preferential adsorption on carbon molecular sieves [34].

3.3. New methodologies for the determination of adsorption capacities and irreversible adsorption from liquid mixtures on selective adsorbents and catalyst supports

The author recently proposed a new approach to the evaluation of adsorbents used for selective adsorption

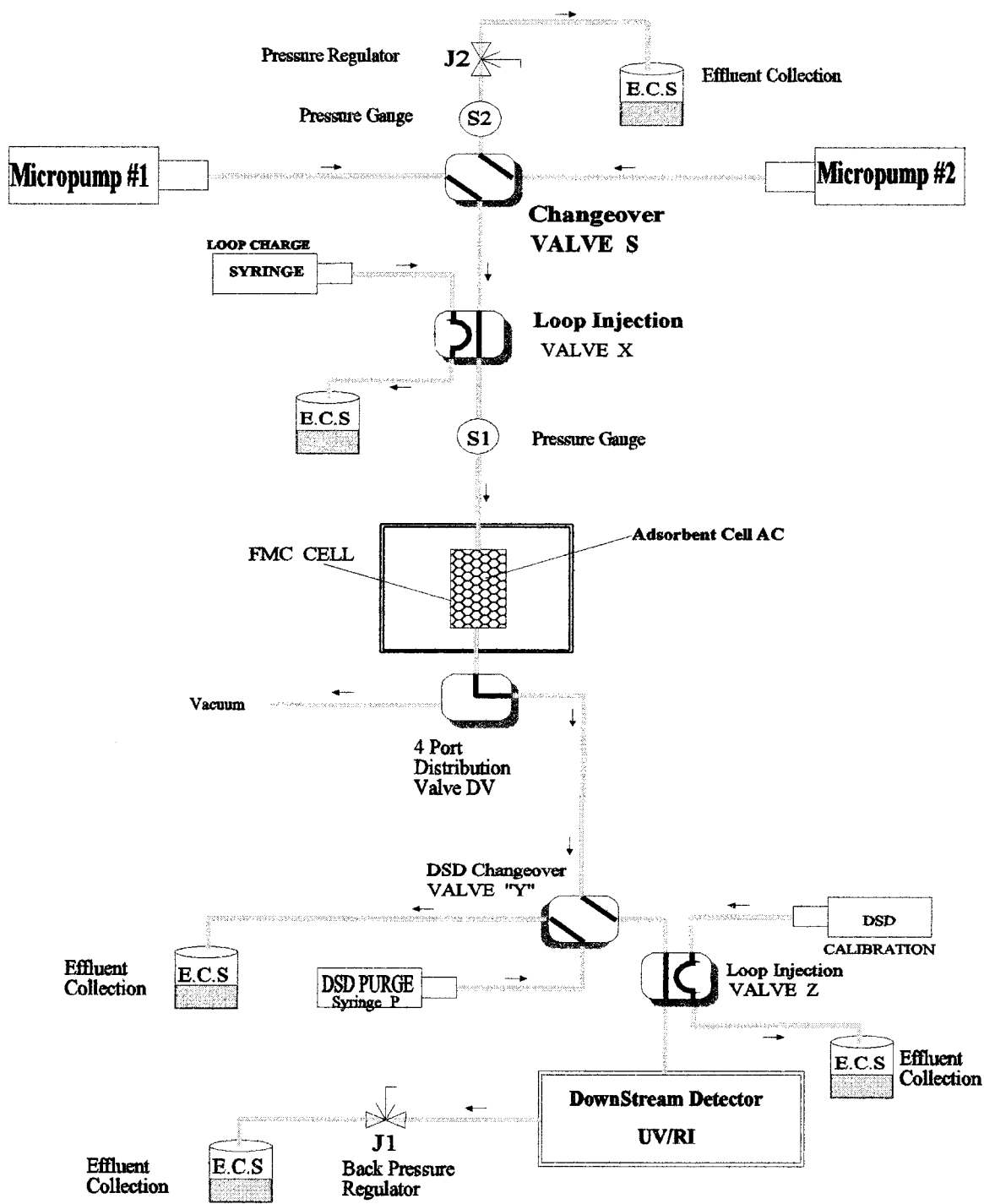

Fig. 4. Adsorption flow chart with DSD.

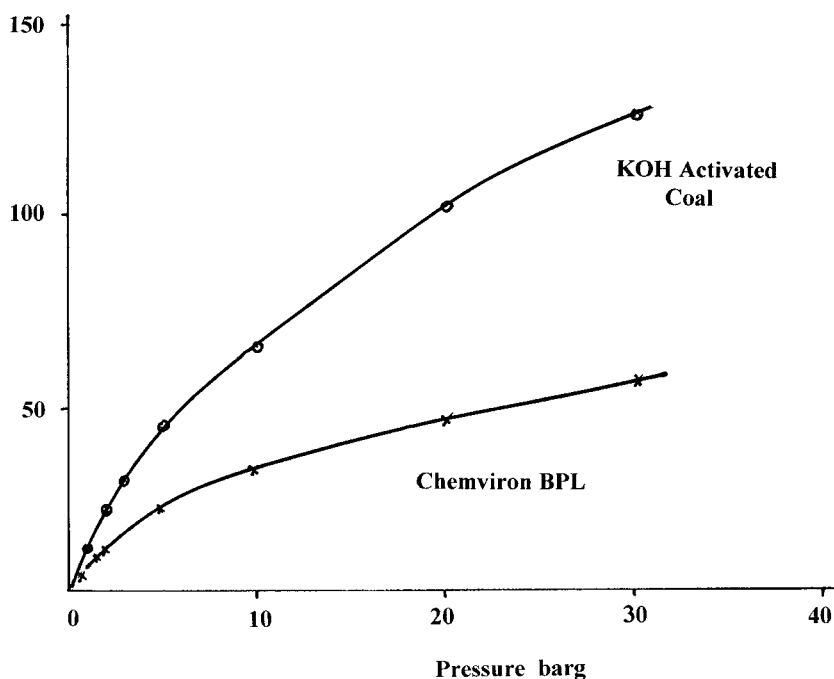

Fig. 5. Cumulative heat of sorption of methane on active carbons. Effect of pressure at 25°C.

processes, such as the adsorption of potassium aurocyanide from water on active carbon. The proposals followed the completion of a three year Eureka Project on the thermodynamic parameters relevant to the industrial recovery of precious metals from aqueous solutions. The work was carried out by the author in conjunction with a manufacturer of active carbons in France (Ste PICA), a CNRS team attached to the University of Montpellier in France and NCRL team at the University of Newcastle in the UK. Initial results of this work are to be published during 1997 [30].

One of the methods involves injection of small volumes of solutions into the stream of carrier liquid percolating through the adsorbent in the calorimetric cell and is designed for the determination of the heats of adsorption of irreversibly adsorbed solutes at increasing degrees of surface coverage. This technique is based essentially on flow-injection analysis techniques, but it is confined to strong interactions between small amounts of active components of fluid mixtures and adsorbents and has been named flow injection adsorption thermodynamics (FIAT). The downstream detector determines the concentration of that part of the injected solute in the effluent which is not retained

by the adsorbent. The heat effect obtained as a result of the injection corresponds only to the strongly (irreversibly) adsorbed component. The relevant differential molar heat of adsorption can, therefore, be accurately determined for a given degree of surface coverage.

The injections can be continued until there is no more irreversible adsorption, i.e. until all the injected solute passes with the effluent to the DSD. At that point all the active sites on the adsorbent are saturated and further adsorption is fully reversible. To speed up the saturation process and reduce the number of injections to saturate the active surface, it is possible to dilute the adsorbent bed in the calorimeter with an inert powder. This is advisable, especially with adsorbents having a very large surface area such as active carbons. In such a case, 5–30 mg of adsorbent can be mixed with ca. 90–65 mg of inert PTFE powder, making up the volume required to fill the calorimetric cell (0.17 cc). A typical example of the FIAT method applied to the determination of differential enthalpies of adsorption illustrated in Fig. 6 for adsorption of potassium chloroplatinate on a graphitised carbon black. The first injection of 0.2 μmol of K_2PtCl_6

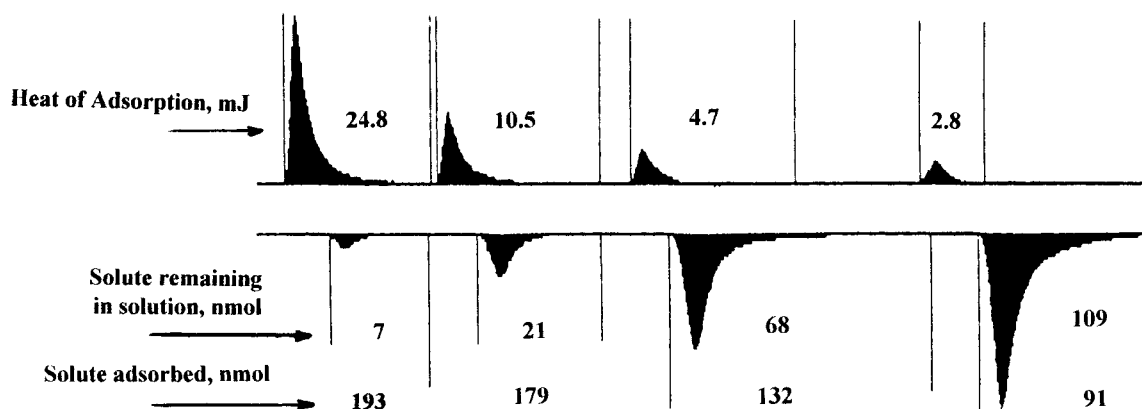

Fig. 6. FIAT methodology: Heats and amounts of adsorption and desorption of potassium chloroplatinate from 20 μl aliquots of 10 mMol solutions in water on 25.8 mg of graphitized carbon black (graphon) mixed with 80 mg of PTFE.

produced a molar heat of adsorption of 128 kJ mol^{-1} and the fourth injection yielded 31 kJ mol^{-1} . The individual adsorptions occur on surface sites of different activity and reflect the heterogeneity of the surface. On the other hand, similar adsorption experiments on alumina produced relatively low heats of adsorptions emphasising the high affinity for transition metal salts of the polar sites present in graphitized carbons [35].

Another methodology is based on the determination of the heats and amounts of adsorption for extended saturation of adsorbent in the calorimetric cell, the time of saturation with a given solution (or gas mixture) being as long as the duration of heat evolution and a steady response of DSD indicating termination of the adsorption process and establishment of an equilibrium between the solute adsorbed on the surface and that present in the solution supplied to the adsorbent. The process can then be reversed by displacing the solution with the solvent which, generally, produces an endotherm and a gradual return of DSD response to that of the pure solvent. The adsorption/desorption cycle can be repeated several times until equality is attained between the heats of adsorption and desorption indicating a state of full adsorption reversibility.

This procedure is named flow equilibrium adsorption thermodynamics (FEAT). It determines the molar heats of adsorption from individual solutions which can be added up to obtain a measure of the integral heats of adsorption. The heats of mixing do not

interfere if the solute concentrations increase in sequential saturation steps which are small enough. Generally, increments of 2 g per litre of solution are satisfactory. This methodology produces differential and integral heats of adsorptions as well as adsorption isotherms. Additionally, if the adsorption/desorption sequences are repeated at different temperatures, evaluation of both free energy ΔG and entropy ΔS of the adsorptions can be obtained, as indicated above. The latter is, of course, very important in the study of adsorption of large molecules and molecules showing a strong tendency to association such as water molecules.

An example of FEAT methodology applies to the adsorption of potassium aurocyanide from 5 mMol solution in water on a graphitised carbon at 25°C is shown in Fig. 7. Of the three adsorption/desorption cycles shown, the first cycle gives higher heat and adsorption values than the subsequent cycles. This shows that there is a small degree of irreversible adsorption on the active sites of the graphitic surface, which are saturated during the first contact with the solution. Subsequent adsorptions appear fully reversible.

The application of FIAT and FEAT methods can be greatly facilitated by the use of a computer controlled automatic sequence controllers (ASC) which are especially useful for the determination of several adsorption-desorption cycles, of relatively long duration, thus offering increased precision, reproducibility and convenience of 24 h round the clock experimental

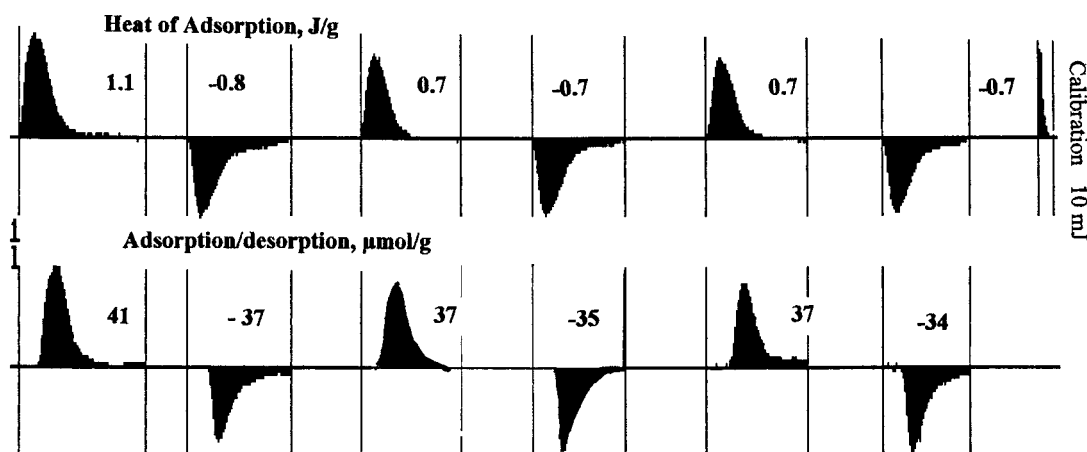

Fig. 7. FIAT methodology: Heats and amounts of adsorption and desorption of potassium aurocyanide from its 5 mMol solution in water on graphitized carbon black.

tion. In many cases, two channel (FMC and DSD) operation can be applied directly to laboratory modelling of plant processes to determine capacities, dynamics and chemical equilibria [36].

The FIAT procedure are of special interest for the characterization of catalyst supports in respect of their capacity for strong irreversible adsorption of catalytically active compounds during impregnation treatments. It is, generally, known that strong adsorption of such compounds on high surface area supports will result in a resistance to sintering and a retention of high dispersion of the catalyst. FIAT methodology can easily show differences between the strength of interactions of various supports and prospective catalysts. An example of such differences are the heats of adsorption of K_2PtCl_6 from aqueous solutions on alumina and a graphitized carbon black. The heats of adsorption on the latter support are much higher at low surface coverages than the heats on alumina [35] and, therefore, the catalytic performance of the alumina–Pt catalyst may be expected to be relatively less effective.

4. Conclusions

Flow adsorption microcalorimetry has now been developed to a point where it provides accurate and reliable adsorption and desorption data for events occurring at solid–liquid interfaces over a wide range

of temperatures, pressures and/or solution concentrations.

The data can be used to obtain thermodynamic parameters characterising the nature of adsorbate–solid interactions which are important in gaining a fundamental understanding of selective adsorption mechanisms, kinetics of adsorption and the associated processes, such as catalysis, lubrication, dispersion technology, corrosion, adhesion and determination of surface areas of chemically different sites on solid surfaces.

References

- [1] A.J. Groszek, *Nature* 182 (1958) 1152–1153.
- [2] G.H. Bell, A.J. Groszek, *Nature* 191 (1961) 1184–1185.
- [3] S. Cerny, V. Ponec, L. Hladek, *J. Chem. Thermodynamics* 2 (1970) 391–397.
- [4] C.E. Templer, *Proc. Particle Size Analysis*, 26, 1970, pp. 4–14.
- [5] N.M. Van Os, G. Haandrikman, *Langmuir* 3 (1987) 1051.
- [6] C.E. Templer, *Nature Physical Sciences* 235 (1972) 158–160.
- [7] A.J. Groszek, *Nature* 204 (1964) 680.
- [8] A.J. Groszek, *Nature* 196 (1962) 531.
- [9] A.J. Groszek, *ASLE Transactions* 13 (1971) 278–287.
- [10] T. Allen, R.M. Patel, *J. Appl. Chem.* 20 (1970).
- [11] A.J. Groszek, *Proc. R. Soc. London B Biol. Sci.* A314, 1970 p. 473.
- [12] A.J. Groszek, *Adsorption at the Solid-Gas & Solid-Liquid Interface*, 1982 Elsevier Sc.Co. pp. 55–67.
- [13] A.J. Groszek, *Liquid Lubrication Technology*, NASA, 1973, pp. 184–191.

- [14] H. Stack & Fletcher, *Symp. on Thermal Analysis & Calorimetry*, 1977, pp. 35–37.
- [15] A.J. Groszek, *WEAR* 18 (1971) 279–289.
- [16] A.J. Groszek, 4th Intl. Conf. on Surfactants 2B (1964) 1015–1027.
- [17] G.L. Andrews, A.J. Groszek, N. Hairs, *ASLE Transactions* 15 (1972) 184–191.
- [18] A.J. Groszek, *Carbon* 25 (1987) 717–722.
- [19] Proceedings of BP Symposium on the significance of the Heats of Adsorption at the Solid-Liquid Interface, BP Research Centre, Sunbury-on-Thames, Middx, A.J. Groszek (Ed.), 1971.
- [20] G.C. McGonigal, R.H. Bernhardt, D.J. Thomson, *Appl. Phys. Letters* 57 (1990) 28.
- [21] K. Morishe, Y. Takami, Y. Yokota, *Physical Review B* 48 (1993) 11.
- [22] A.J. Groszek, *Chemistry and Industry*, 1966, 1754.
- [23] A.J. Groszek, S. Partyka, *Langmuir* 9 (1993) 2721–2725.
- [24] A.I. Foster, P.G. James, J.J. McCarroll, S.R. Tennison, British Patent No. 1565 074, 1980.
- [25] S.T. Joslin, M. Fowkes, *Ind. Eng. Prod. Res. Dev.* 24 (1985) 369–375.
- [26] F.H. Fowkes, Y. C. Huang, B.A. Shah, M.J. Kulp, T.B. Lloyd, *Colloids & Surfaces* 29 (1988) 243–261.
- [27] A.J. Groszek, Preprints 11th IUPAC Conference on Chem. Thermodynamics, Como, Italy, August 26–31, 1990, pp. 534–535.
- [28] Z. Kiraly, I. Dekany, *Prgr. Colloid Polymer Science* 83 (1990) 68–74.
- [29] Z. Kiraly, I. Dekany, *Farad Transactions* 85 (1989) 3373.
- [30] S. Lagerge, J. Zajac, S. Partyka, A.J. Groszek, M. Chesnau, *Langmuir*, to be published in 1997.
- [31] A.J. Groszek, Extended Abstracts, *Carbon* 94, 3–8 July, Granada, Spain, 1964, pp. 260–261.
- [32] M.L. Sykes, H. Chagger, K.M. Thomas, *Carbon* 31, 1993, pp. 827–832.
- [33] A.J. Groszek, Fuel Chemistry Division, Preprints ASC Meeting, March 1996, New Orleans, 1996, pp. 317–320.
- [34] A.J. Groszek, *Carbon*, to be published in August 1997.
- [35] A.J. Groszek, Extended Abstract, 22nd Biennial Conference on Carbon, 16–21 July, 1995, pp. 450–451.
- [36] H. Goldner, *R&D Magazine*, 1993, p. 53.